



ART 249PRO H685

GUIDE SIGE - SIGE SLIDES - COULISSES SIGE - GUIAS SIGE

REV 00.2023

FOIST00381

SIGE S.P.A.

60020 POLVERIGI (AN) ITALY

TEL +39 071 90 90 000 R.A. - FAX +39 071 90 90 804

WWW.SIGE-SPA.IT INFO@SIGE-SPA.IT

PRODOTTO ED ASSEMBLATO IN ITALIA / MADE AND ASSEMBLED IN ITALY / FABRIQUÉ ET ASSEMBLÉ EN ITALIE / HECHO Y MONTADO EN ITALIA

CARATTERISTICHE • FEATURES • CARACTÉRISTIQUES • CARACTERÍSTICAS

Cestello in lamiera verniciata con guide sinistre ad estrazione totale ammortizzate.
pull-out baskets with painted metal sheet and full extension left slides, soft closing.
Panier en tôle peinte, coulisses gauches à extraction totale avec soft.
Cesto en chapa pintada, guías izquierdas a extracción total y soft.

MINUTERIA INTERNA • FITTINGS • FERRURE • FERRETERIA

N° 12 4x16 mm Viti autoflettanti / Self-tapping screws / Vis auto-taradeuses / Tornillos autorroscantes

N° 6 6,3x12 Eurovite / Eurovite / Eurovite / Eurovite

N° 9 M5x5 mm Viti / Screws / Vis / Tornillos

COMPONENTI • PARTS • COMPOSANTS • COMPONENTES

A. N°1 Cesti / Baskets / Paniers / Cestos

B. N°1 Set guide sx / Kit left slides / Kit coulisses gauches / Set de guías izquierdas

C. N°3 Staffe per fissaggio antina / Door brackets / Pattes fixation porte / Estribos para ajuste de puerta

D. N°3 Piastrini / Plates / Plaques / Placas

E. N°3 Cover

UTENSILERIA • TOOLS • OUTILS • INSTRUMENTOS



MANUTENZIONE • MAINTENANCE • ENTRETIEN • MANTENIMIENTO

Pulire con un panno morbido ed asciutto. Evitare l'uso di solventi e/o abrasivi.

Clean with a soft, dry cloth. Avoid using solvents or abrasive.

Nettoyez avec un chiffon sec et doux. N'utilisez pas aucun solvant ou produit abrasif.

Limpiar con paño suave y seco. Evitar el uso de solventes y/o abrasivos.

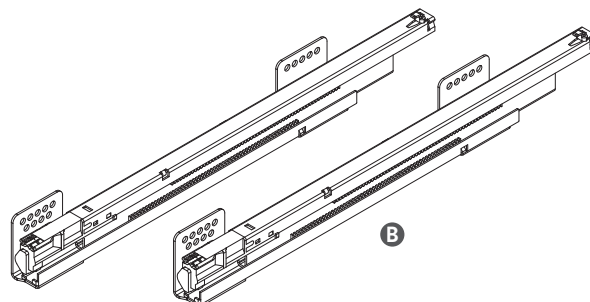
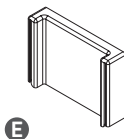
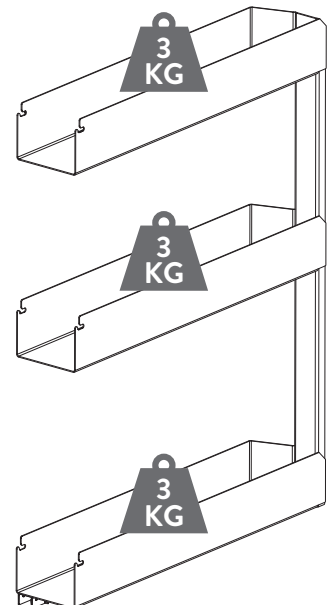
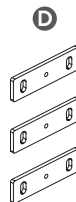
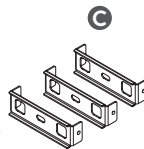
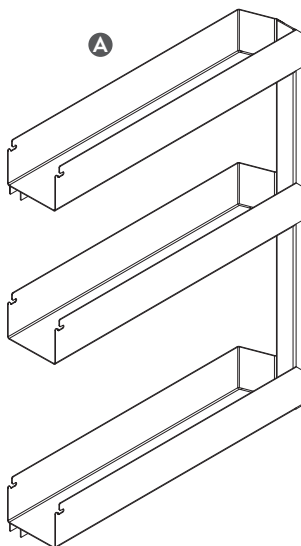
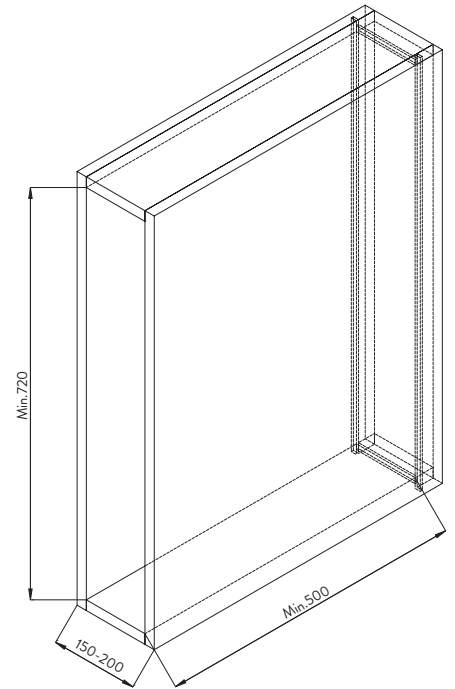

N°12 4x16



1

Posizionare le guide B rispettando le quote ed avvitare con le apposite viti.
Place slides B respecting showed data and screw them.
Positionnez les coulisses B en respectant les mesures indiquées et serrez les vis.
Posicionar las guías B respetando las medidas y atornillar con sus debidos tornillos.

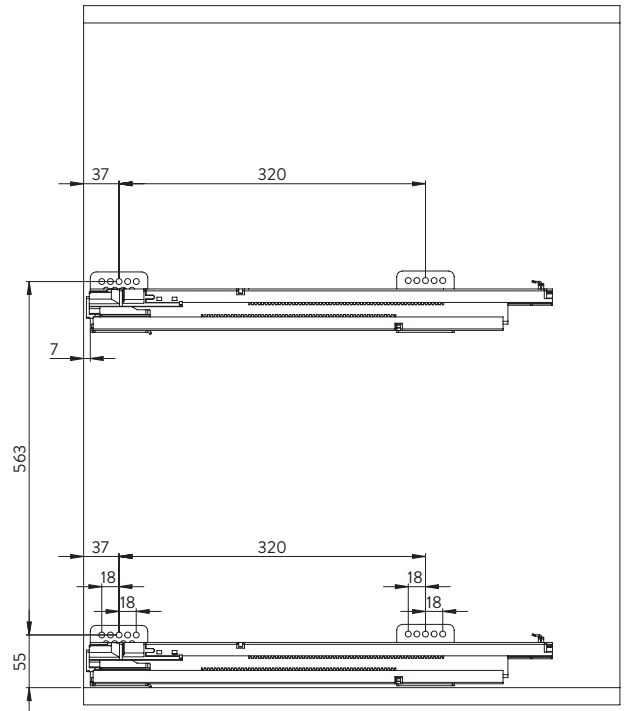
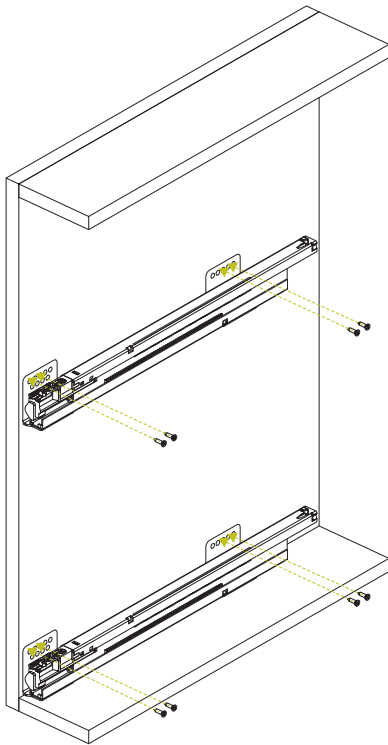

2

Montare il cesto sulle guide B.
Fit basket on slides B.
Monter le panier sur les coulisses B.
Montar el cesto sobre las guías B.

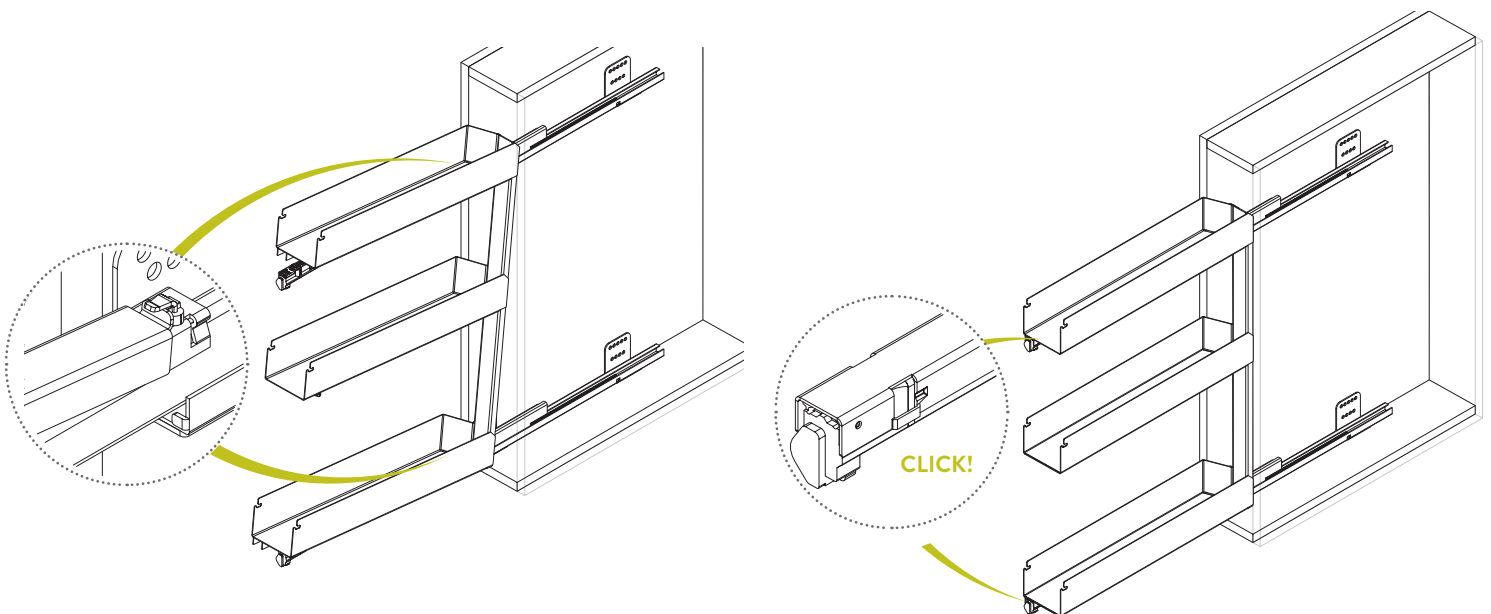

3

N°6 6.3x14



Preforare l'anta ($\varnothing 5 \times 10 \text{ mm}$) rispettando le quote, montare i piastrini D con le sei euroviti 6.3x14.

Pre-drill the door ($\varnothing 5 \times 10 \text{ mm}$) respecting showed data, mount the plates D with the six euroviti 6.3x14.

> <	A	B
L 150	60	24,5
L 200	100	29,5

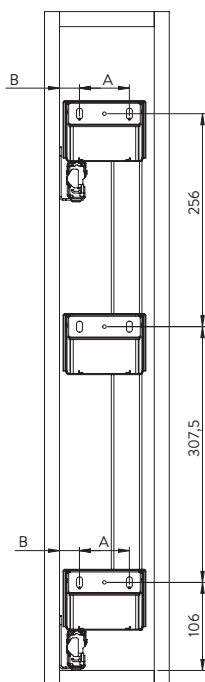

Pré-percez la porte ($\varnothing 5 \times 10 \text{ mm}$) en respectant les données indiquées, montez les plaques D avec les six eurovites 6.3x14.

Perfore previamente la puerta ($\varnothing 5 \times 10 \text{ mm}$) respetando los datos mostrados, ajuste las placas D con los seis eurovites 6.3x14.

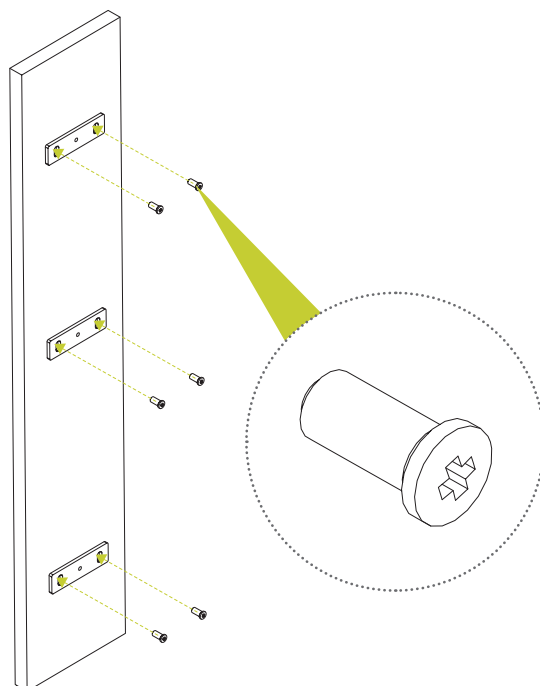

4

N°6 M5x5



Montare le staffe C sul cesto.
Fix the brackets C on the basket.
Monter le pattes C au panier.
Montar los estribos C en la cesta.

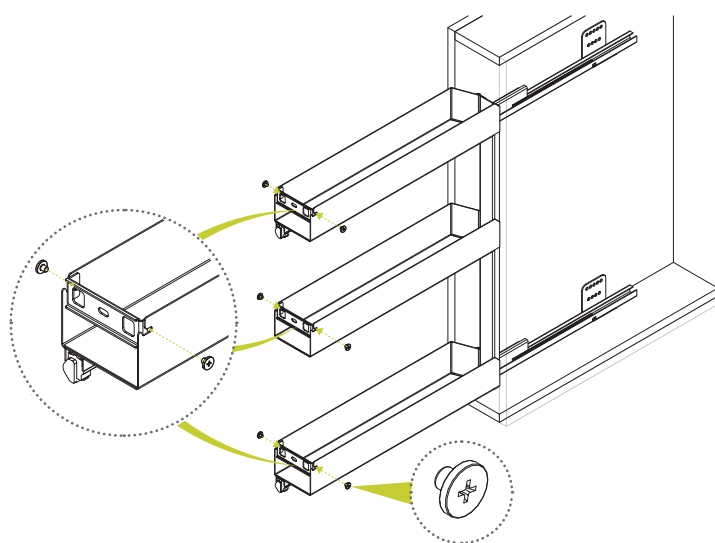

5

N°3 M5x5



Montare l'anta sul cesto tramite le staffe C e D, fissare con quattro viti M5x5 se cesto L150 oppure con sei viti M5x5 se cesto L200.

Fix the door to the basket with the brackets C and D, fix with four M5x5 screws if W150 basket or with six M5x5 screws if W200 basket.

Monter la porte sur le panier avec les pattes de fixation C et D, fixer avec quatre vis M5x5 si panier L150 ou avec six vis M5x5 si panier L200.

Instalar la puerta sobre el cesto con las escuadras C y D, fijelo con cuatro tornillos M5x5 si los cestos L150 o con seis tornillos M5x5 si los cestos L200.

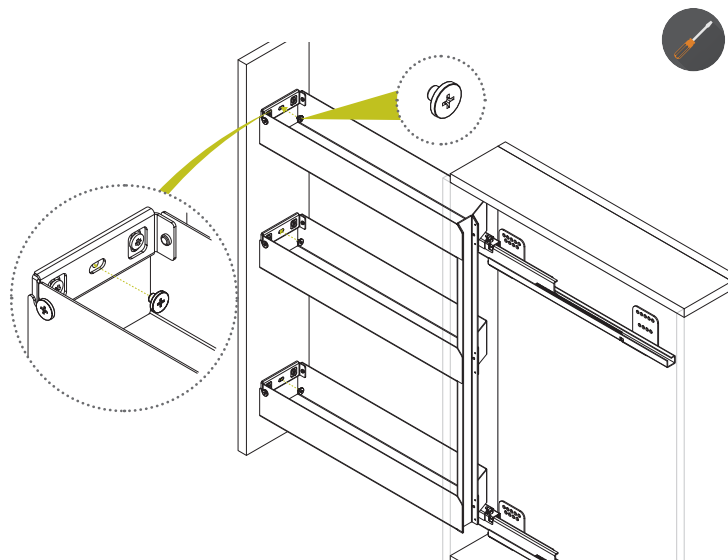

6

Allentare le sei M5x5 sui fianchi del cesto per regolare l'antina avanti indietro.
Loosen the six M5x5 on the sides of the basket to adjust the front door backwards.
Desserrez les six M5x5 sur les côtés du panier pour ajuster la porte avant vers l'arrière.
Afloje los seis M5x5 a los lados de la cesta para ajustar la puerta delantera hacia atrás.

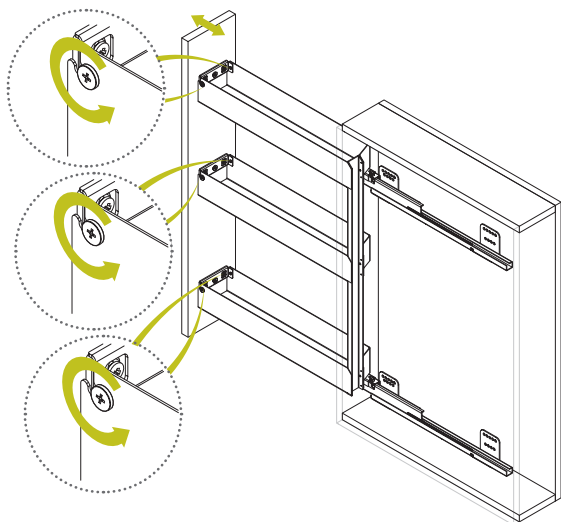

7

Allentare le tre M5x5, come mostrato, per regolare l'antina a destra ed a sinistra.
Loosen the three M5x5, as shown, to adjust the door to the right and left.
Desserrez les trois M5x5, comme indiqué, pour ajuster la porte à droite et à gauche.
Afloje los tres M5x5, como se muestra, para ajustar la puerta a la derecha y a la izquierda.

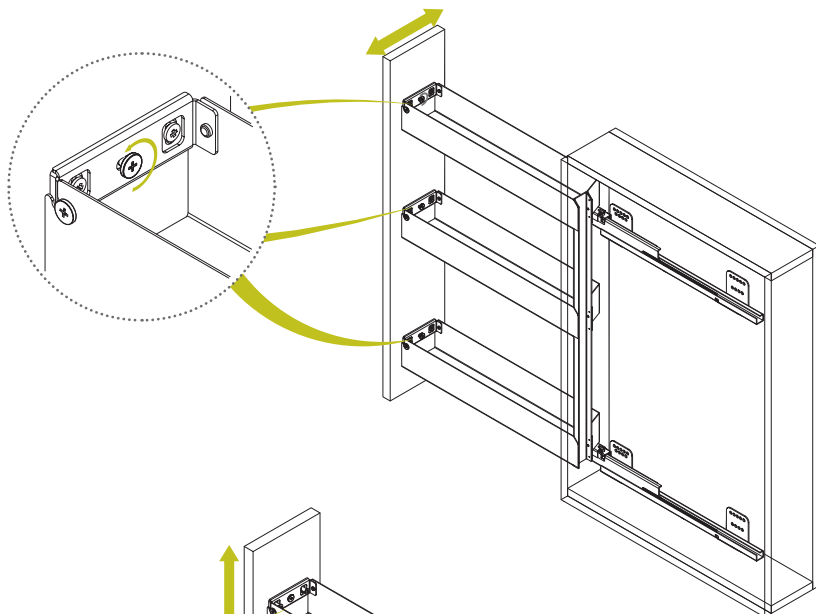

8

Allentare le sei 6.3x14, come mostrato, per regolare l'antina su e giù.
Loosen the six 6.3x14, as shown, to adjust the door up and down.
Desserrez les six 6.3x14, comme indiqué, pour ajuster la porte de haut en bas.
Afloje los seis 6.3x14, como se muestra, para ajustar la puerta hacia arriba y hacia abajo.

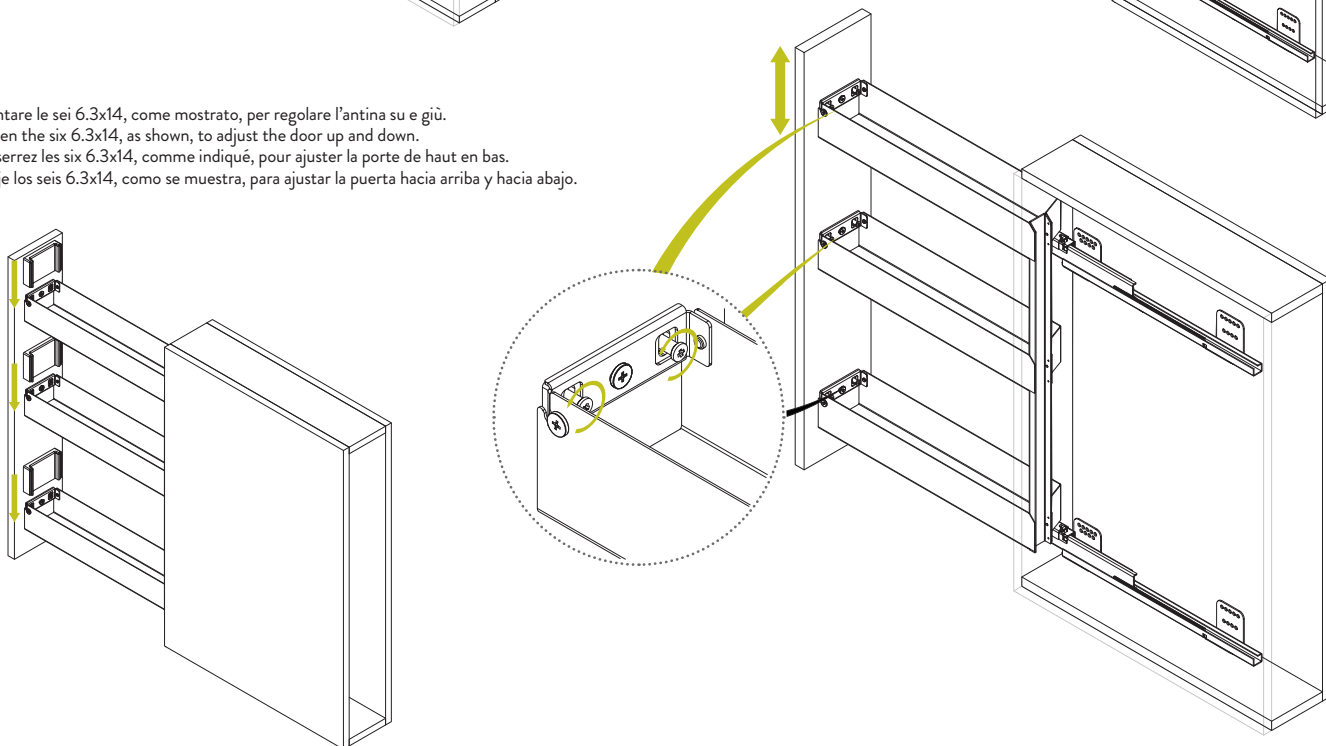

9

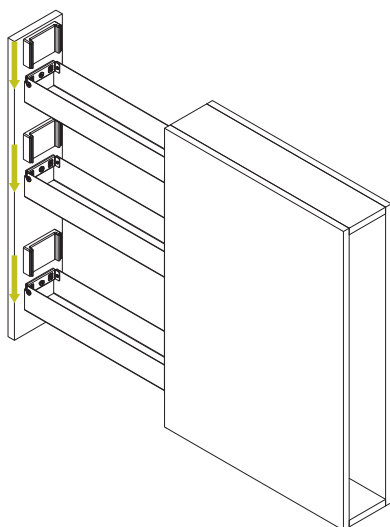

OPTIONAL

Inserire gli optional. / Insert the optionals.
Insérer les options. / Inserte las opciones.

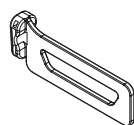

N°4 Divisorio
N°4 Divider
N°4 Séparateurs
N°4 Divisorios

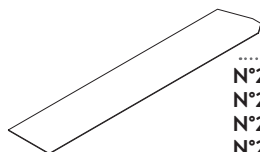

N°2 Tappetino
N°2 Mat
N°2 Tapis
N°2 Esterilla

